

# LH53259

## CMOS 256K (32K × 8) Mask-Programmable ROM

### FEATURES

- 32,768 words × 8 bit organization
- Access time: 150 ns (MAX.)
- Low-power consumption:
  - Operating: 137.5 mW (MAX.)
  - Standby: 550 μW (MAX.)
- Programmable output enable
- Static operation
- TTL compatible I/O
- Three-state outputs
- Single +5 V power supply
- Packages:
  - 28-pin, 600-mil DIP
  - 28-pin, 450-mil SOP
  - 28-pin, 8 × 13.4 mm<sup>2</sup> TSOP (Type I)
- JEDEC standard EPROM pinout (DIP)

### DESCRIPTION

The LH53259 is a mask-programmable ROM organized as 32,768 × 8 bits. It is fabricated using silicon-gate CMOS process technology.

### PIN CONNECTIONS

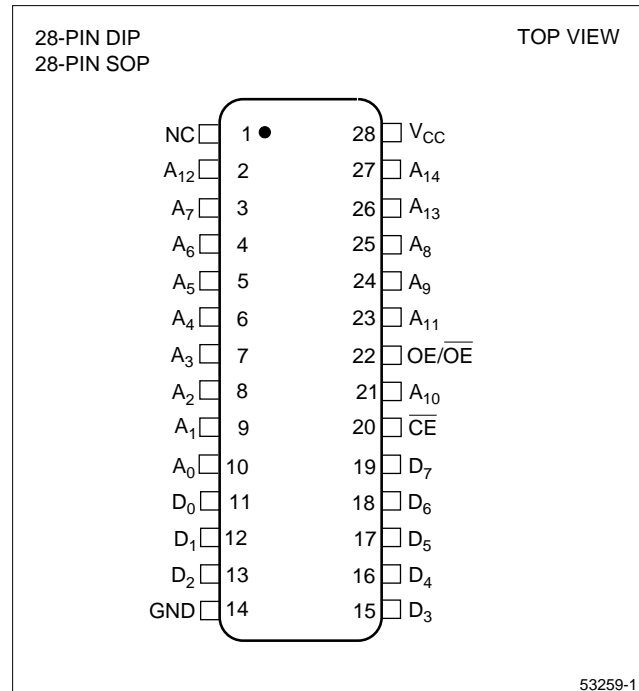

Figure 1. Pin Connections for DIP and SOP Packages

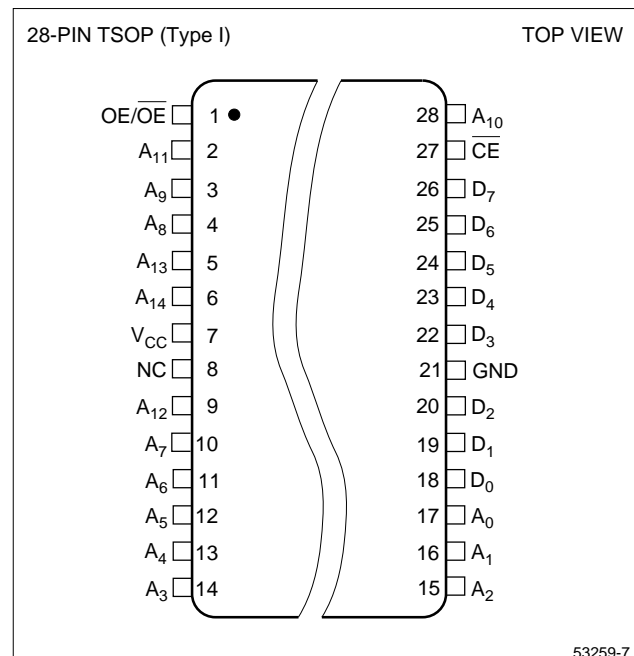

Figure 2. Pin Connections for TSOP Package

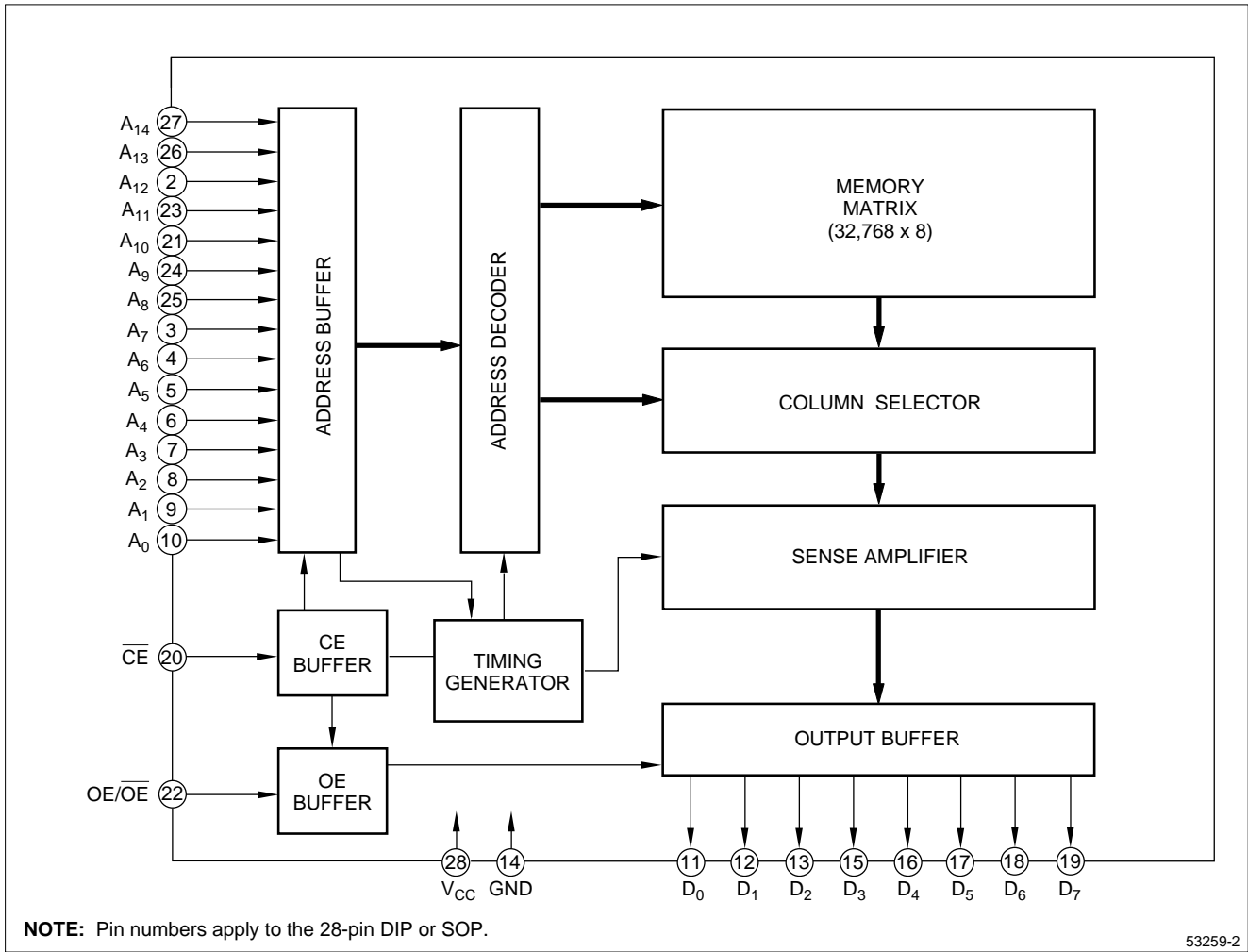

Figure 3. LH53259 Block Diagram

**PIN DESCRIPTION**

SIGNAL	PIN NAME	NOTE
A <sub>0</sub> – A <sub>14</sub>	Address input	
D <sub>0</sub> – D <sub>7</sub>	Data output	
$\overline{CE}$	Chip enable input	
OE/ $\overline{OE}$	Output enable input	1

SIGNAL	PIN NAME	NOTE
V <sub>CC</sub>	Power supply (+5 V)	
GND	Ground	
NC	No connection	

**NOTE:**

1. The active level of OE/ $\overline{OE}$  is mask-programmable.

**TRUTH TABLE**

$\overline{CE}$	OE/ $\overline{OE}$	MODE	D <sub>0</sub> - D <sub>7</sub>	SUPPLY CURRENT	NOTE
H	X	Non selected	High-Z	Standby	1
L	L/H				
	H/L	Selected	D <sub>OUT</sub>	Operating	

**NOTE:**

1. X = H or L

**ABSOLUTE MAXIMUM RATINGS**

PARAMETER	SYMBOL	RATING	UNIT
Supply voltage	$V_{CC}$	-0.3 to +7.0	V
Input voltage	$V_{IN}$	-0.3 to $V_{CC} + 0.3$	V
Output voltage	$V_{OUT}$	-0.3 to $V_{CC} + 0.3$	V
Operating temperature	$T_{opr}$	0 to +70	°C
Storage temperature	$T_{stg}$	-55 to +150	°C

**RECOMMENDED OPERATING CONDITIONS ( $T_A = 0$  to +70°C)**

PARAMETER	SYMBOL	MIN.	TYP.	MAX.	UNIT
Supply voltage	$V_{CC}$	4.5	5.0	5.5	V

**DC CHARACTERISTICS ( $V_{CC} = 5\text{ V} \pm 10\%$ ,  $T_A = 0$  to +70°C)**

PARAMETER	SYMBOL	CONDITIONS	MIN.	TYP.	MAX.	UNIT	NOTE
Input 'Low' voltage	$V_{IL}$		-0.3		0.8	V	
Input 'High' voltage	$V_{IH}$		2.2		$V_{CC} + 0.3$	V	
Output 'Low' voltage	$V_{OL}$	$I_{OL} = 1.6\text{ mA}$			0.4	V	
Output 'High' voltage	$V_{OH}$	$I_{OH} = -400\text{ }\mu\text{A}$	2.4			V	
Input leakage current	$ I_{LI} $	$V_{IN} = 0\text{ V to }V_{CC}$			10	$\mu\text{A}$	
Output leakage current	$ I_{LO} $	$V_{OUT} = 0\text{ V to }V_{CC}$			10	$\mu\text{A}$	1
Operating current	$I_{CC1}$	$t_{RC} = 150\text{ ns}$			25	mA	2
	$I_{CC2}$	$t_{RC} = 1\text{ }\mu\text{s}$			20		
	$I_{CC3}$	$t_{RC} = 150\text{ ns}$			20	mA	3
	$I_{CC4}$	$t_{RC} = 1\text{ }\mu\text{s}$			15		
Standby current	$I_{SB1}$	$\overline{CE} = V_{IH}$			2	mA	
	$I_{SB2}$	$\overline{CE} = V_{CC} - 0.2\text{ V}$			100		$\mu\text{A}$
Input capacitance	$C_{IN}$	$f = 1\text{ MHz}$			10	pF	
Output capacitance	$C_{OUT}$	$T_A = 25^\circ\text{C}$			10		pF

**NOTES:**

- $\overline{CE}/\overline{OE} = V_{IH}$  or  $\overline{OE} = V_{IL}$
- $V_{IN} = V_{IH}/V_{IL}$ ,  $\overline{CE} = V_{IL}$ , outputs open
- $V_{IN} = (V_{CC} - 0.2\text{ V})$  or  $0.2\text{ V}$ ,  $\overline{CE} = 0.2\text{ V}$ , outputs open

**AC CHARACTERISTICS ( $V_{CC} = 5\text{ V} \pm 10\%$ ,  $T_A = 0$  to +70°C)**

PARAMETER	SYMBOL	MIN.	TYP.	MAX.	UNIT	NOTE
Read cycle time	$t_{RC}$	150			ns	
Address access time	$t_{AA}$			150	ns	
Chip enable access time	$t_{ACE}$			150	ns	
Output enable time	$t_{OE}$	10		80	ns	
Output hold time	$t_{OH}$	5			ns	
CE to output in High-Z	$t_{CHZ}$			70	ns	1
OE to output in High-Z	$t_{OHZ}$			70	ns	

**NOTE:**

- This is the time required for the output to become high impedance.

## AC TEST CONDITIONS

PARAMETER	RATING
Input voltage amplitude	0.6 V to 2.4 V
Input rise/fall time	10 ns
Input reference level	1.5 V
Output reference level	0.8 V and 2.2 V
Output load condition	1TTL + 100 pF

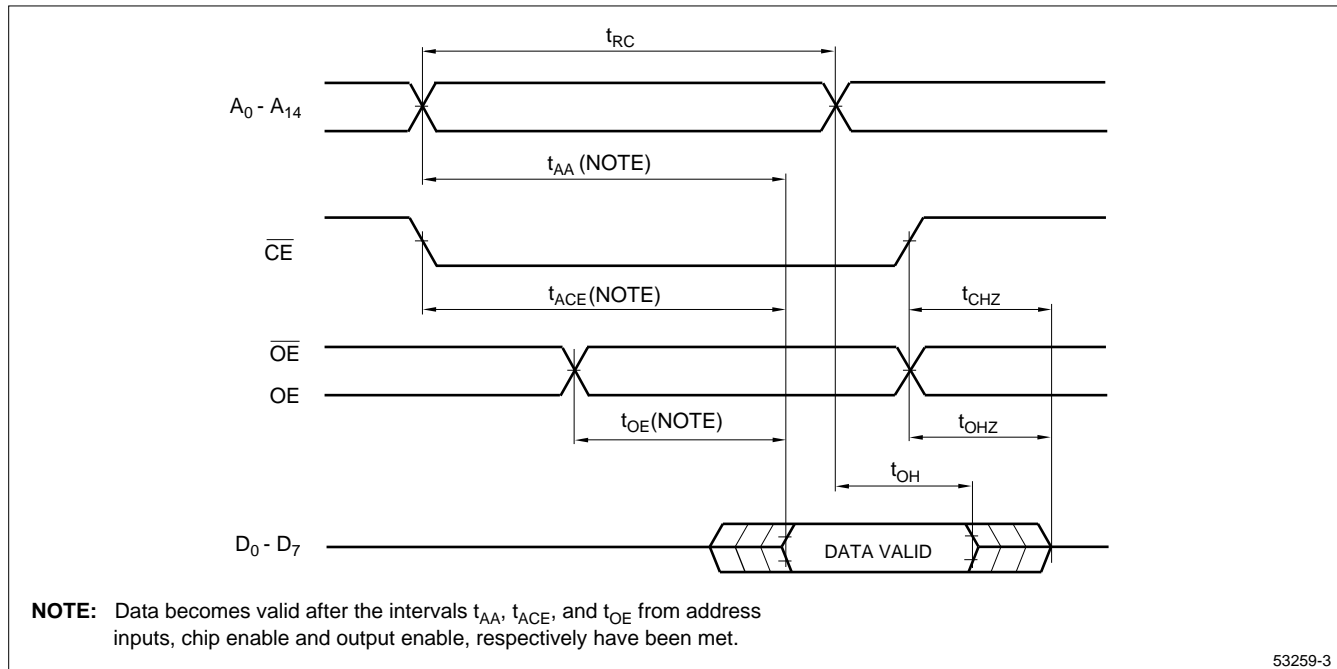
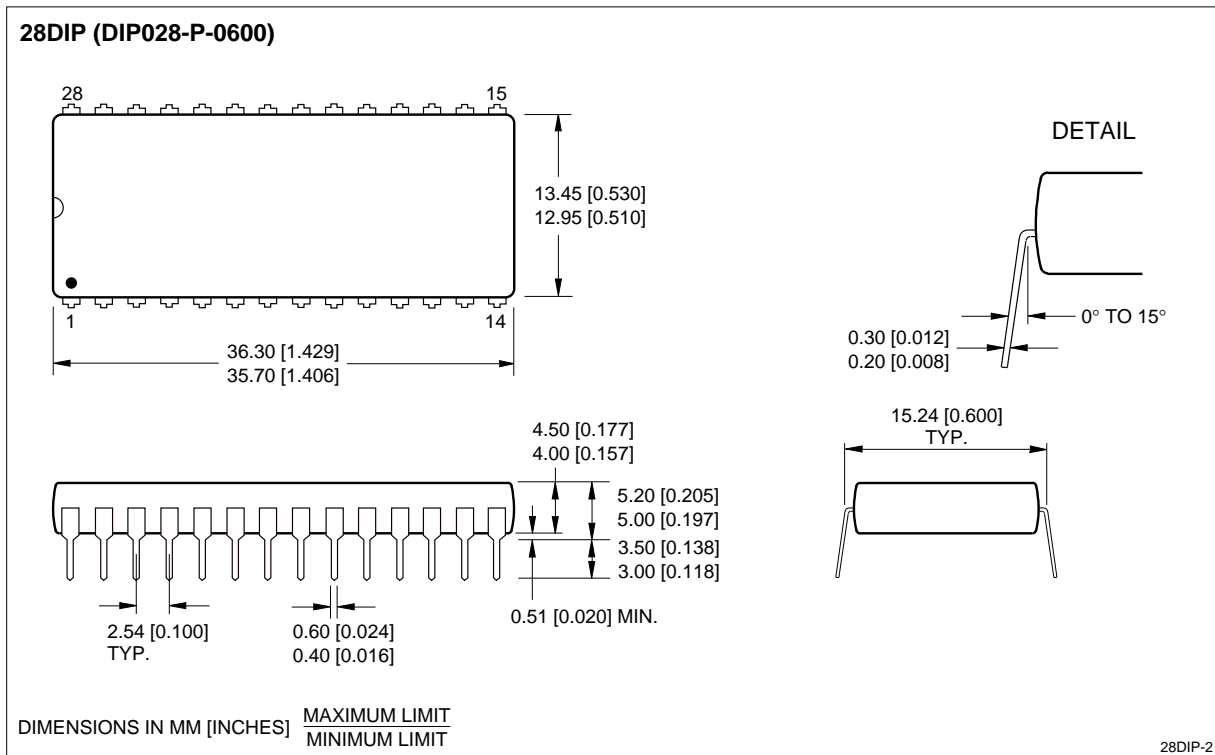
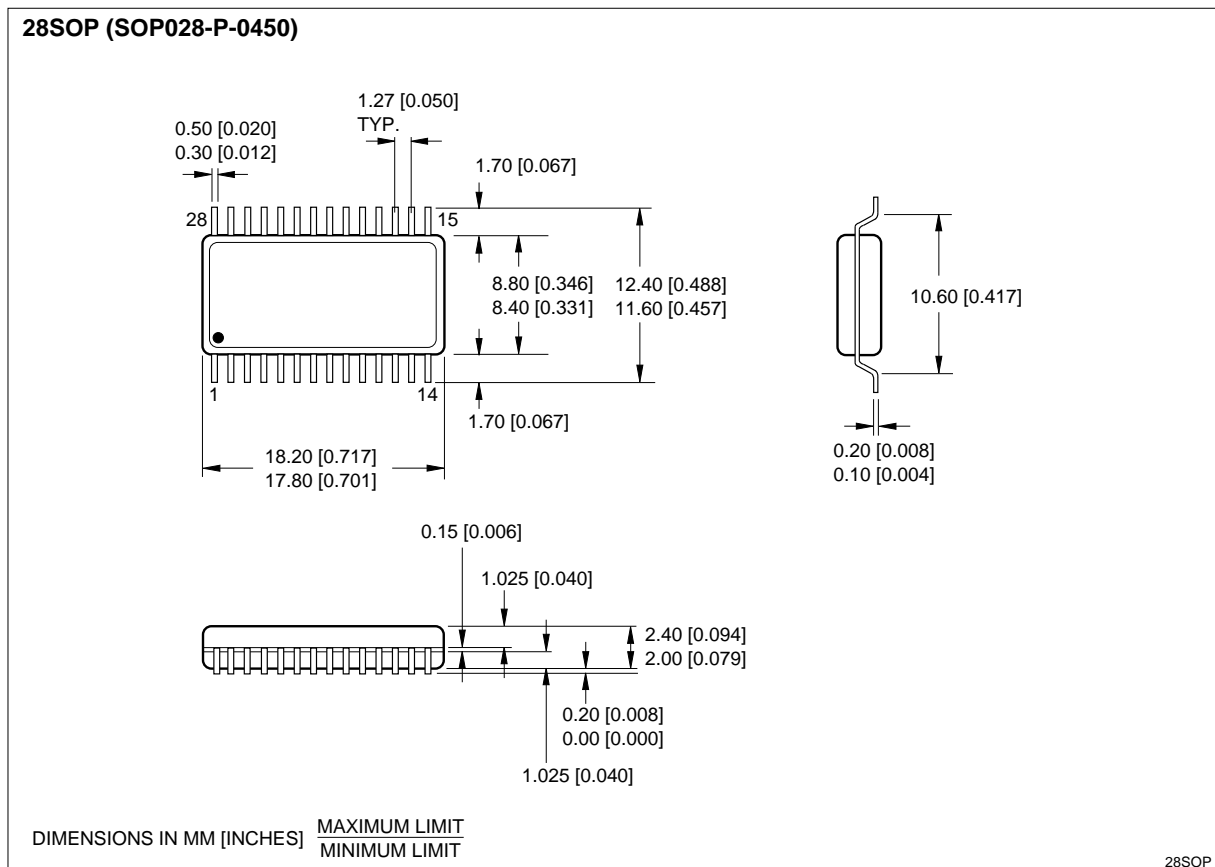

Figure 4. Timing Diagram

PACKAGE DIAGRAMS



28-pin, 600-mil DIP



28-pin, 450-mil SOP

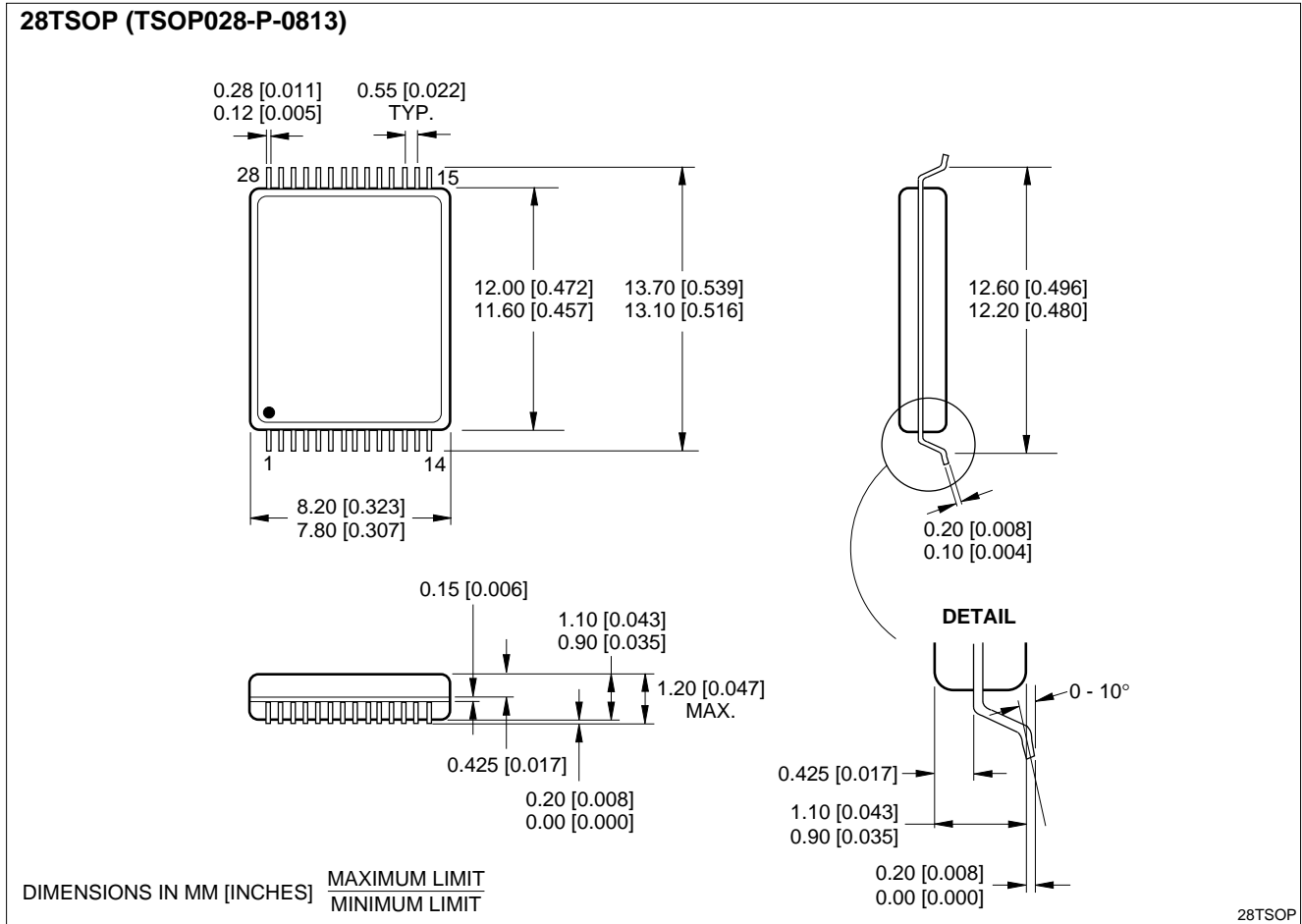

**28-pin, 8 × 13.4 mm<sup>2</sup> TSOP (Type I)**

**ORDERING INFORMATION**

